



Software House Product Companion

Wiring Convention and Supplemental Guide to
Software House PSX Pre-Wired Power Management Systems

Contents

Introduction.....	3
Standard Conventions.....	4
System Wiring Example.....	8
Typical Wiring - SWH Controllers.....	14
Typical Wiring - PSX Power Boards.....	17

Introduction

Traditional wiring for access control systems is time consuming and labor intensive. SWH pre-wired systems take PSX power solutions to a new higher level of service by pre-wiring all lock and system power connections to Software House[™] terminal strips for easy plug-and-play installation.

Prewired features of PSX power systems include access control or system power, lock power, auxiliary power distribution, lock control, and optional remote management.

One or more D8 power distribution modules provides individually fused outputs for auxiliary devices. Each D8 module provides eight protected outputs capable of 3A per output and a configuration jumper to select which power supply is applied to a specific output in dual voltage systems.

The field connected locks are powered and controlled from either a C8 or M8 lock control module with a separate dedicated power supply typically configured for 24VDC. Each C8 or M8 module provides either jumpers or software programmability to configure each individual output for 12 or 24VDC, FAI operation, and failsafe or failsecure operation of the lock when triggered by the access control.

Optional remote management allows direct integration with C•CURE9000 to provide the ability to monitor and control the power system directly through the C•CURE9000 interface. Scheduled remote battery testing, individual output power cycle and more are also available through C•CURE9000.

Units of eight or sixteen door capacity are available with wire tie or wire duct wire management, depending on enclosure.

Standard Conventions

The following section presents the conventions used within this document for board labeling and placement, output usage, and wire coloring.

Software House Board Numbering

Software House board locations are numbered as S1, S2, etc. in sequence, from top to bottom.

The GCM controller will always be located in the S1 location.

See Typical Enclosure Configurations on page 5 for examples.

PSX Power Board Numbering

LifeSafety Power board locations are numbered with the board type and a number to indicate individual boards. Locations with multiple designations may have either board or may have both boards stacked, depending on configuration.

PSX-1 Lock Power - 12 or 24V

PSX-2 System Power (12V) in large Dual Voltage Systems

B100 System Power (12V) in small Dual Voltage Systems

D8-1 to D8-n Power Distribution, Fused

C8-1 / M8-1 Lock Control for locks 1 - 8

C8-2 / M8-2 Lock Control for locks 9 - 16

Software House Board Mounting

Mounting of the Software House subassemblies are by means of the supplied 6-32 SEMS screws using the preinstalled hex standoffs.

 Do not overtighten the hardware during the install process.

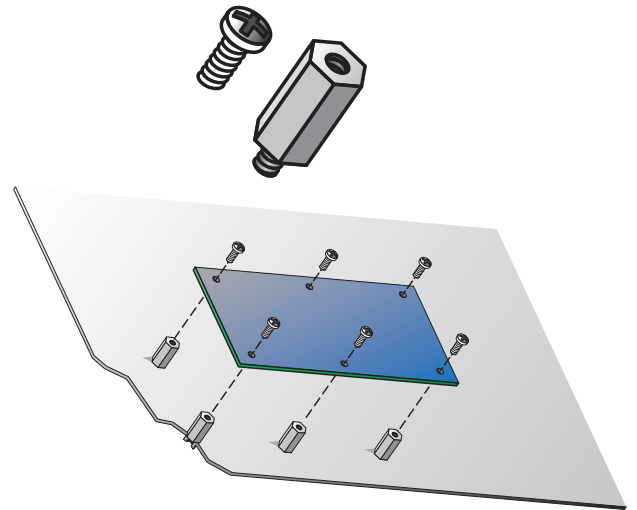



Typical System Configurations



8 Door - E6S Ultra/SE

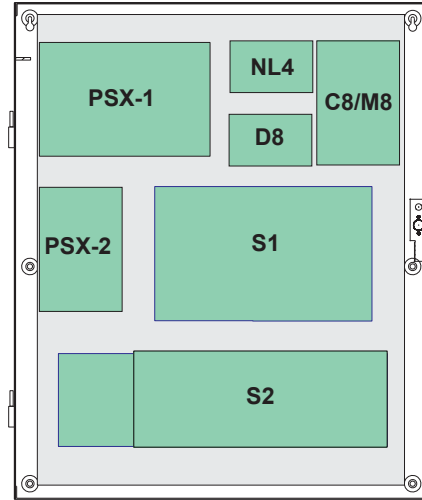

8 Door - E4S Ultra/SE



16 Door - E6S Ultra/SE

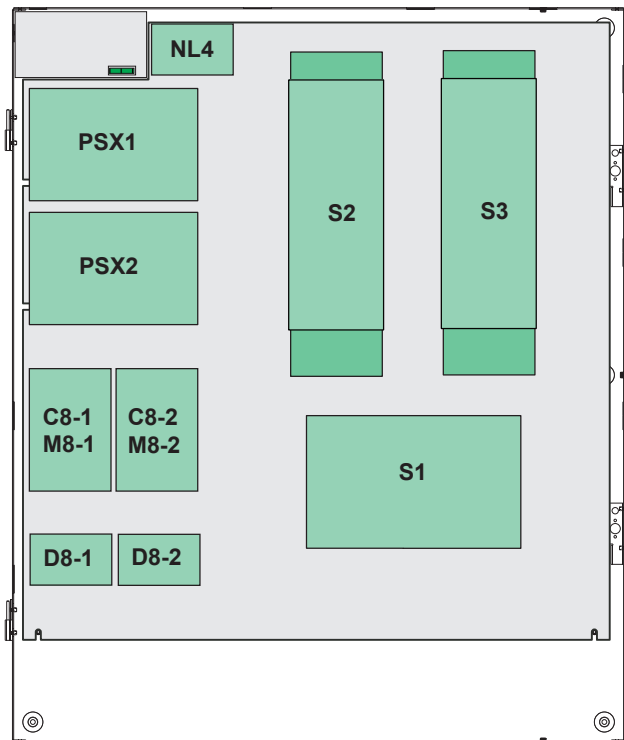

16 Door - E8S Ultra/SE

Wiring Conventions

Wiring within the enclosure uses a consistent method and wire coloring as detailed below.

Software House Board Power Connections

Software House Board power originates from the 12V supply (PSX-2 or B100). Power is supplied to the Software House boards from the DC1 output of the PSX supply or DC OUT of the B100. Software House board power wiring uses twisted 18AWG wire.

Red: +12VDC

Black: Ground (-)

Lock Control Input Color Code to C8/M8 from ACM Outputs

The wiring between the ACM outputs and the C8 or M8 Lock Control board inputs uses twisted 18AWG wire with the following color convention:

Output 1: Brown / Black

Output 2: Red / Black

Output 3: Orange / Black

Output 4: Yellow / Black

Output 5: Green / Black

Output 6: Blue / Black

Output 7: Violet / Black

Output 8: Gray / Black

Wire coloring repeats for inputs 9-32 on additional C8/M8 boards

SWH PSX Standard Conventions Quick Reference

Software House Board Numbering

- S1 - GCM
- S2 - ACM 1
- S3 - ACM 2
- S4 - ACM 3
- S5 - ACM 4

LSP Board Numbering

- FPO1 - Lock power
- FPO2 or B100 - 12V System power
- D8-1 to D8-n - D8 power distribution
- C8-1/M8-1 Lock control for locks 1 - 8
- C8-2/M8-2 Lock control for locks 9 - 16
- C8-3/M8-3 Lock control for locks 17 - 24
- C8-4/M8-4 Lock control for locks 25 - 32

Software House Board Power

- 12VDC
- Red +12VDC
- Black GND
- Twisted 18 AWG
- From DC1 of PSX-2 or DC OUT of B100

Lock Control Input Color Code to C8 / M8 from Access Control

- 1 - Brown / Black twisted 18 AWG
- 2 - Red / Black twisted 18 AWG
- 3 - Orange / Black twisted 18 AWG
- 4 - Yellow / Black twisted 18 AWG
- 5 - Green / Black twisted 18 AWG
- 6 - Blue / Black twisted 18 AWG
- 7 - Violet / Black twisted 18 AWG
- 8 - Gray / Black twisted 18 AWG
- Repeat for inputs 9 - 16 on C8-2/M8-2
- Repeat for inputs 17 - 24 on C8-3/M8-3
- Repeat for inputs 25 - 32 on C8-4/M8-4



System Wiring Example

The following pages show an overview of wiring for a typical prewired system. Details of the wiring for each board are in later sections.

PSX Power Board, Fault, and Tamper Switch Wiring - Ultra & SE

The PSX power boards are prewired for power, Fault, and FlexIO. PSX-1 is wired to the B1 buss, and PSX-2 is wired to the B2 buss. FlexIO daisychains between all of the accessory boards to provide fault and FAI throughout the system. Fault wiring uses the PSX power supply's NO contacts for System and AC fault and connects to the GCM fault input. See LSP AN-19 for more information on the Dual Buss architecture used for accessory power.

NOTE: iSTAR Ultra shown - Wiring is the same for Ultra SE systems.

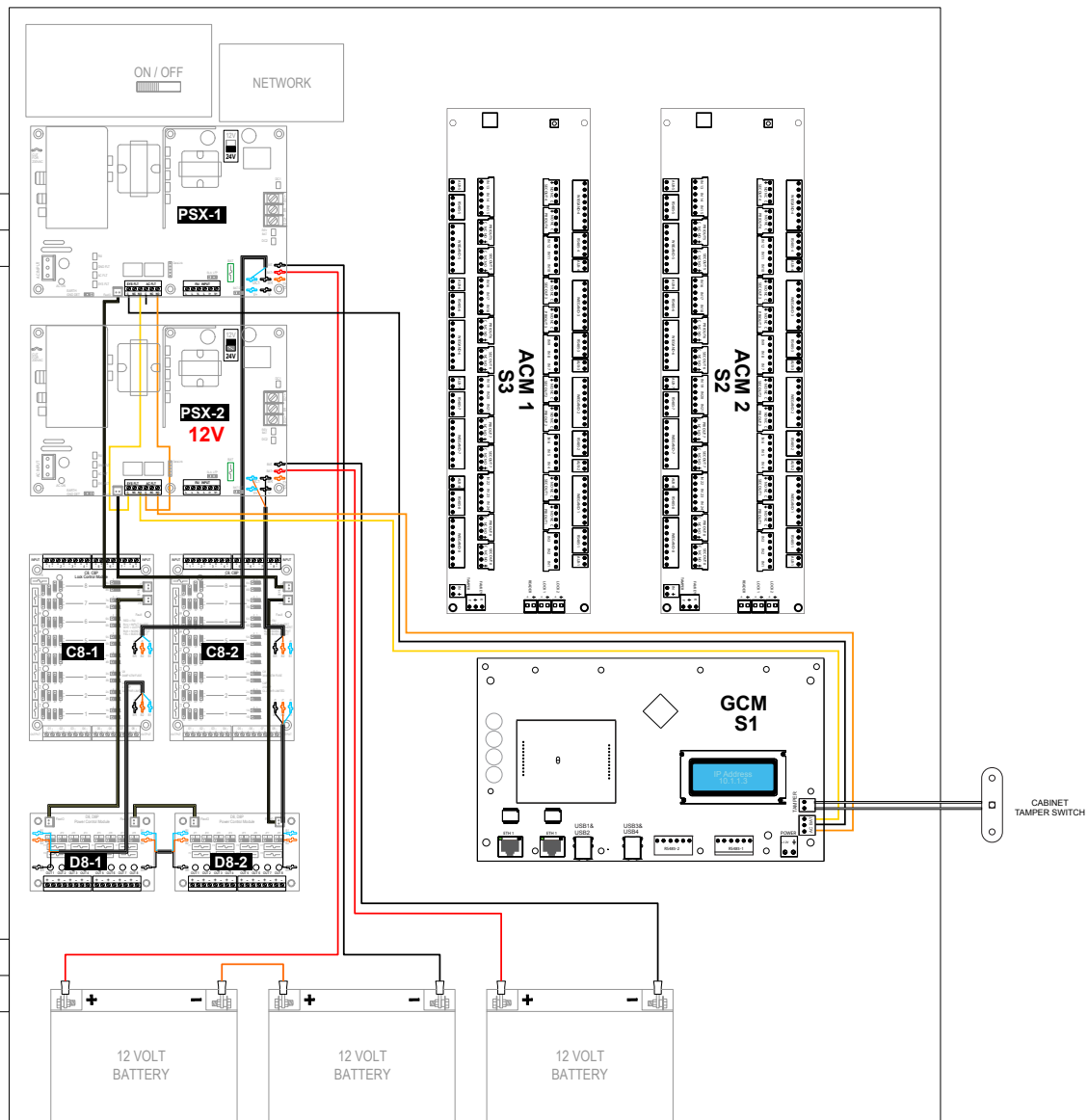

System Wiring Example

Software House Board Power Wiring - Ultra

The Ultra GCM and ACM(s) are prewired for power to PSX-2 or the B100.

Wiring is red/black twisted pair.

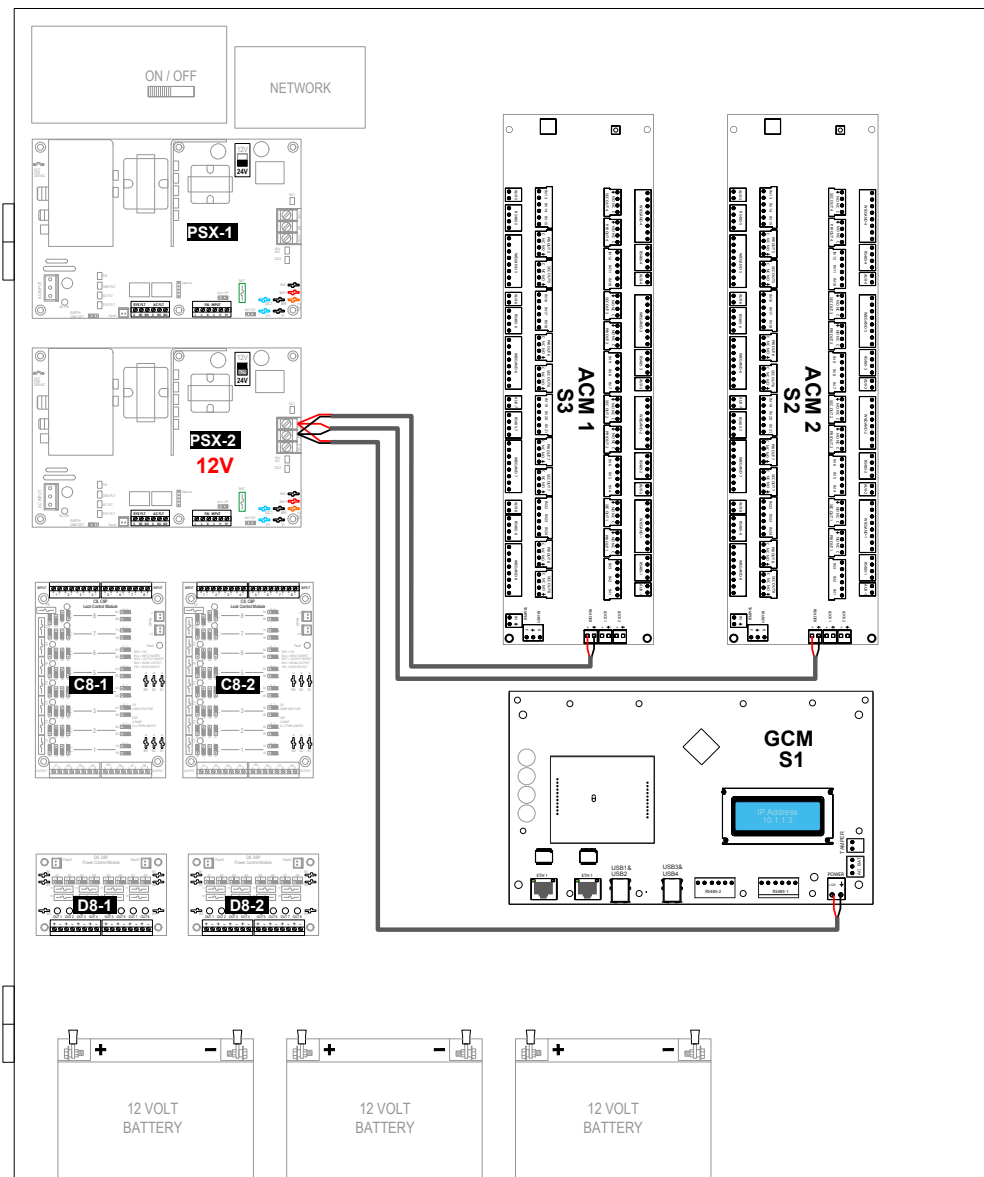

System Wiring Example

Software House Board Power Wiring - Ultra SE

The Ultra SE GCM and ACM(s) are prewired for power to PSX-2 or the B100. Wiring is red/black twisted pair.

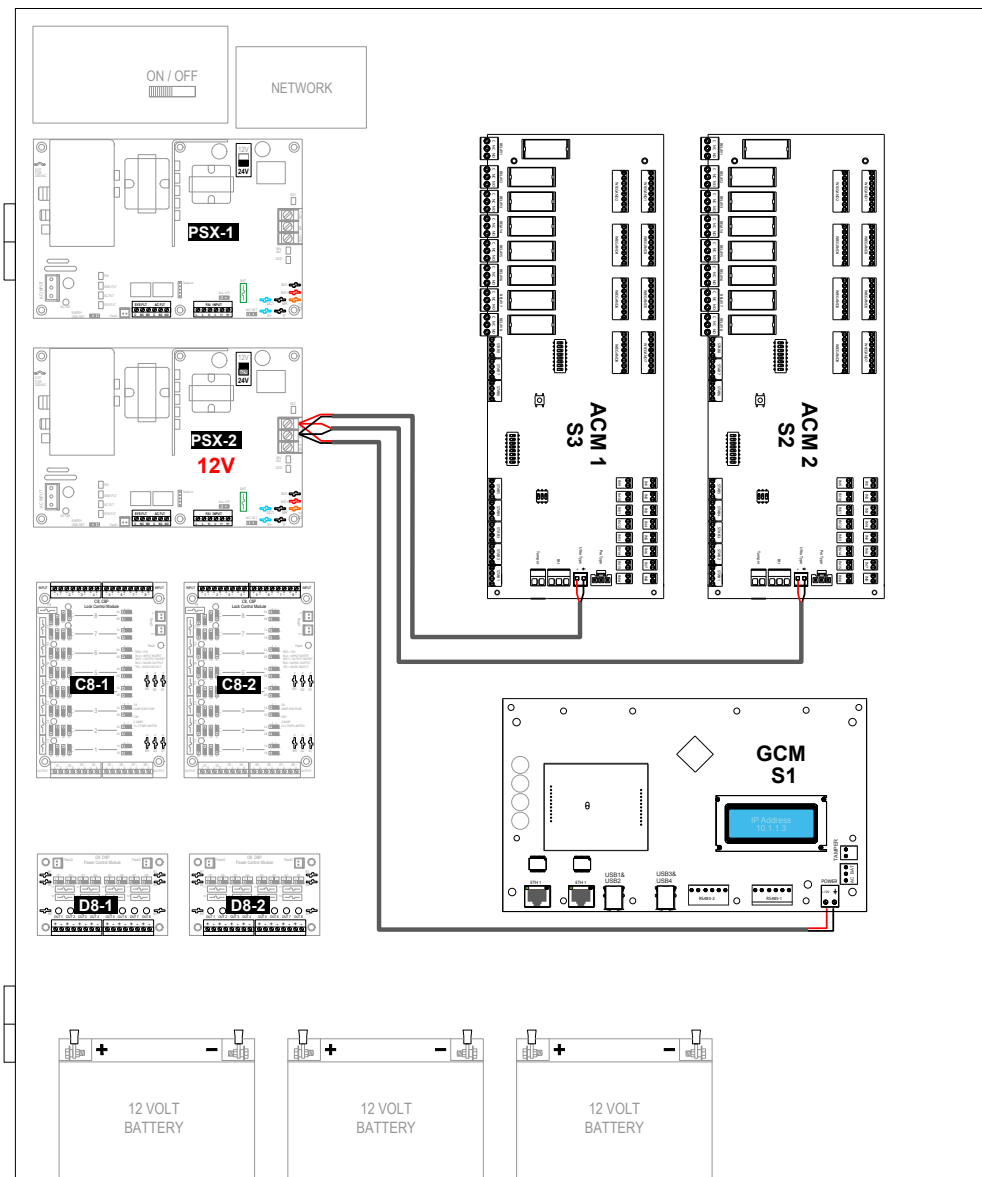

System Wiring Example

Software House Board Output Relay Wiring - Ultra

The output lock relays of the Ultra ACM board(s) are prewired to the inputs of the C8 or M8 lock control boards. Wiring is twisted pair and is color coded. ACM relays should be configured as a dry output.



System Wiring Example

Software House Board Output Relay Wiring - Ultra SE

The output lock relays of the Ultra SE ACM board(s) are prewired to the inputs of the C8 or M8 lock control boards. Wiring is twisted pair and is color coded.



Typical Wiring - iSTAR GCM

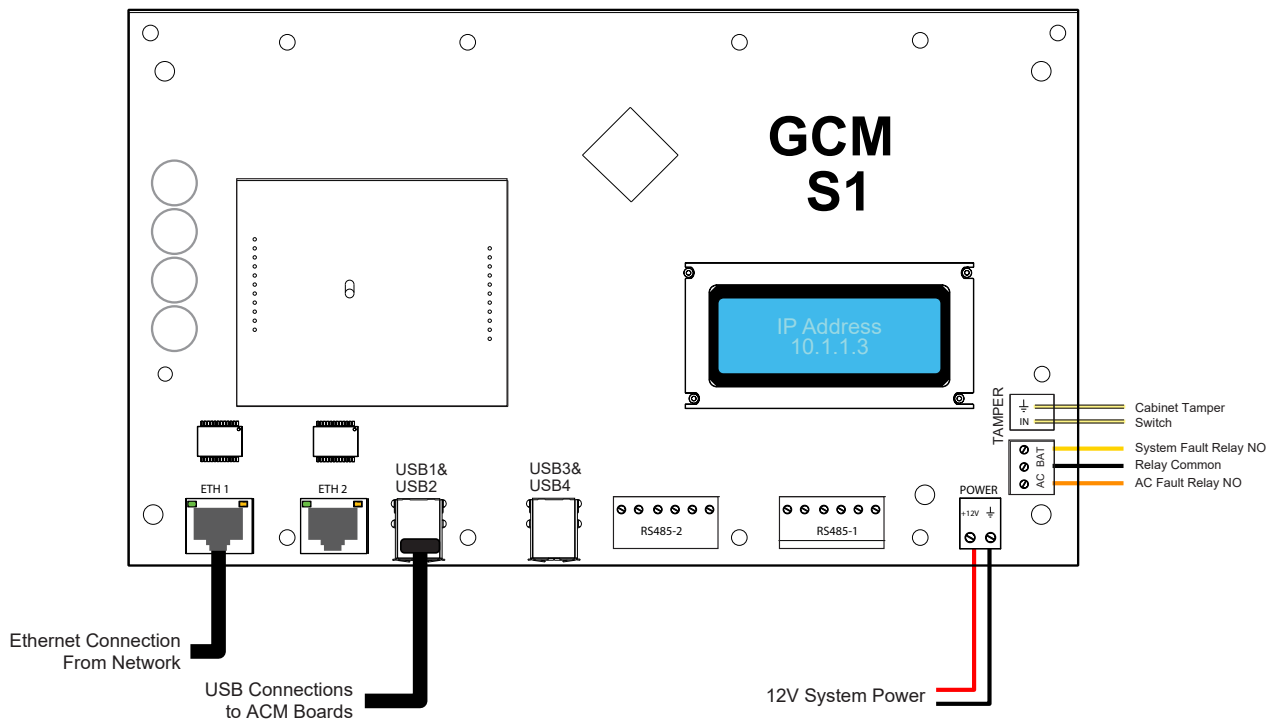

The iSTAR GCM controller provides decision making, event reporting, and database storage for the Mercury hardware platform. Two reader interfaces provide control for two doors.

Communication between connected boards is by means of the integrated USB ports.

A maximum of four iSTAR Ultra or Ultra SE ACM boards may be connected to the GCM for a total of 32 doors.

The GCM requires 12VDC for power and is connected to 12VDC supplied from PSX-2 or a B100. Care must be taken to avoid connecting 24V to the GCM or immediate damage will occur.

Mechanical mounting is by eight, supplied, 1/2" metal standoffs threaded into the enclosure backplate with the board secured to the standoffs with eight 6-32 x 3/8" machine screws.

For electrical connection, remove the appropriate terminal strips from the board and replace with the supplied, pre-wired and identified terminal strips.

Typical Wiring - iSTAR Ultra ACM

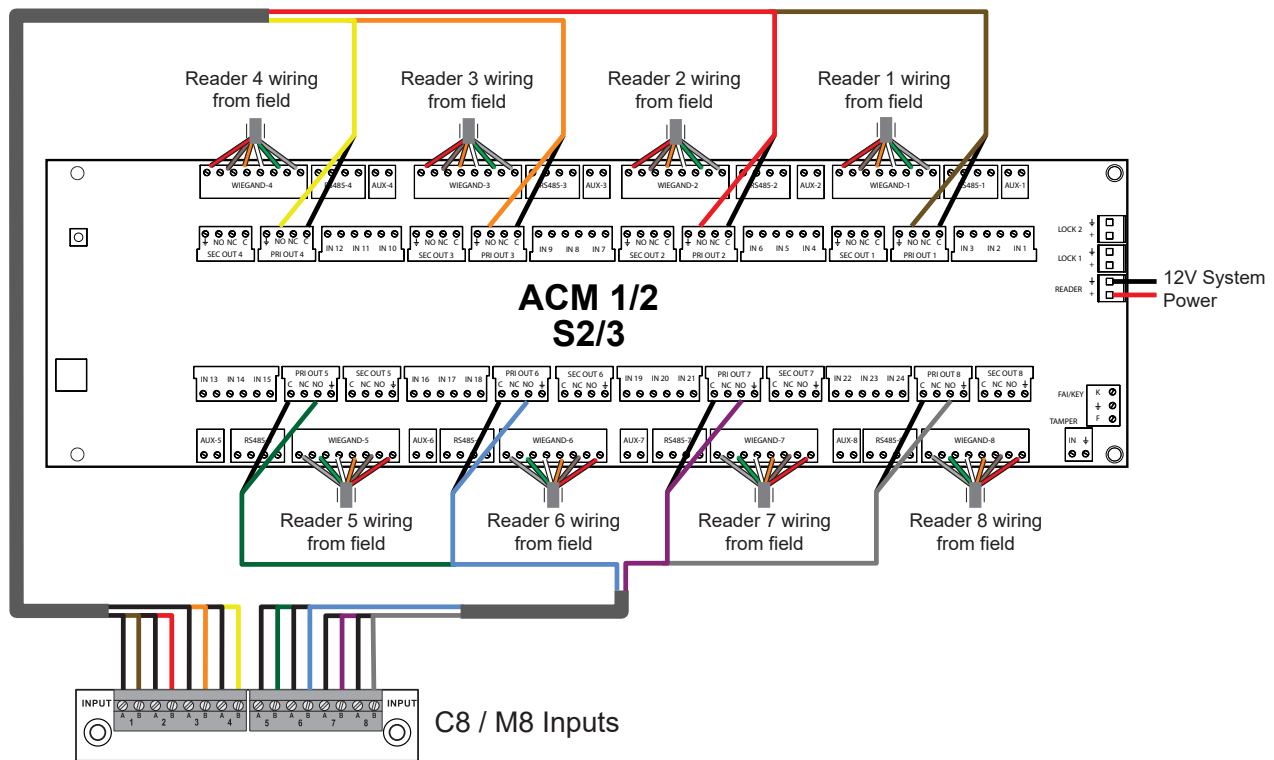

The iSTAR Ultra ACM interfaces to the readers and door hardware. Eight Wiegand and RS-485 inputs allow for connection of up to eight readers.

Sixteen form-C relay outputs (8 Primary, 8 Secondary) may be used for door control or alarm signaling.

Communication to the GCM is accomplished via USB port.

The ACM requires 12VDC for reader/system power and is connected to 12VDC supplied from PSX-2 or a B100. The lock power inputs are unused in systems with C8/M8 lock control boards.

The lock outputs (PRI OUT 1 through PRI OUT 8) of the ACM are connected to the C8/M8 inputs such that the ACM activates the C8/M8 lock control board and the C8/M8 activates the lock. This method adds another layer of control to the lock and protection for the Software House hardware.

Typical Wiring - iSTAR Ultra SE ACM

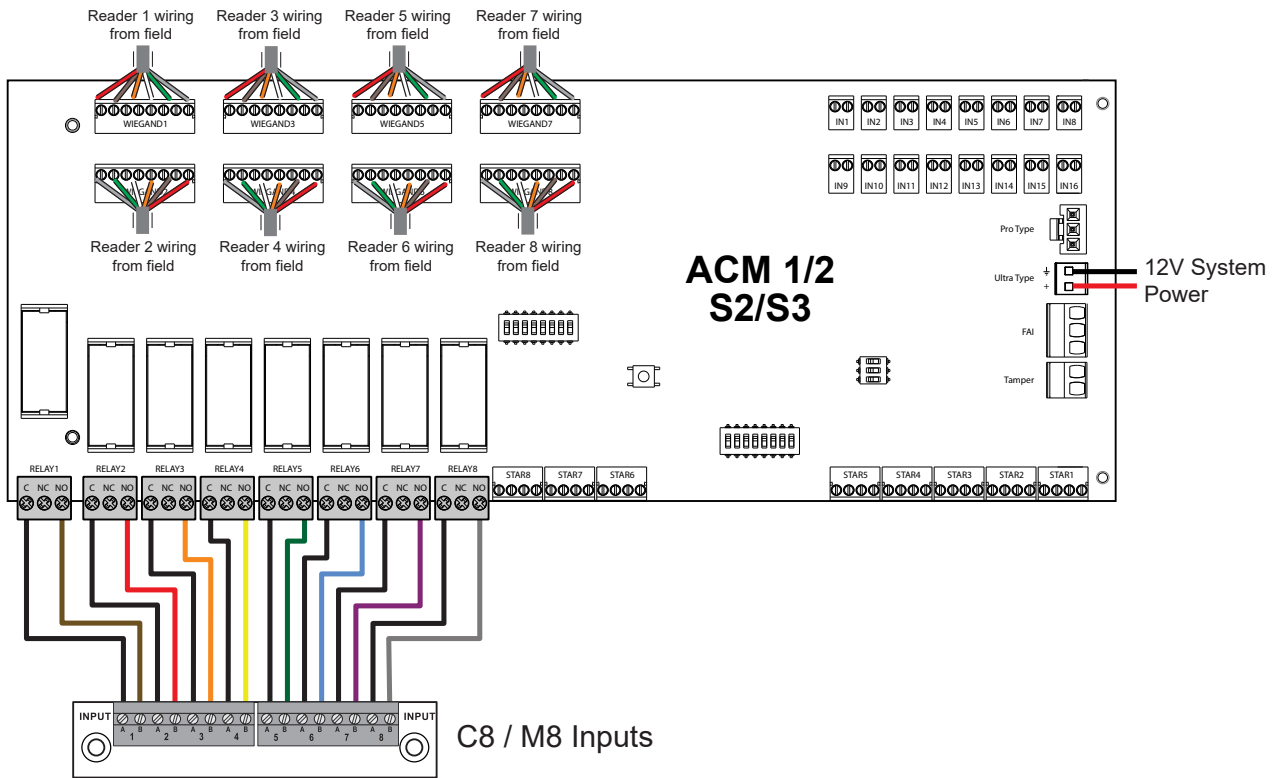

The iSTAR Ultra SE ACM interfaces to the readers and door hardware. Eight Wiegand and RS-485 inputs allow for connection of up to eight readers.

Sixteen form-C relay outputs (8 Primary, 8 Secondary) may be used for door control or alarm signaling.

Communication to the GCM is accomplished via USB port.

The ACM requires 12VDC for reader/system power and is connected to 12VDC supplied from PSX-2 or a B100.

The lock outputs (PRI OUT 1 through PRI OUT 8) of the ACM are connected to the C8/M8 inputs such that the ACM activates the C8/M8 lock control board and the C8/M8 activates the lock. This method adds another layer of control to the lock and protection for the Software House hardware.

Typical Wiring - PSX150 / PSX250

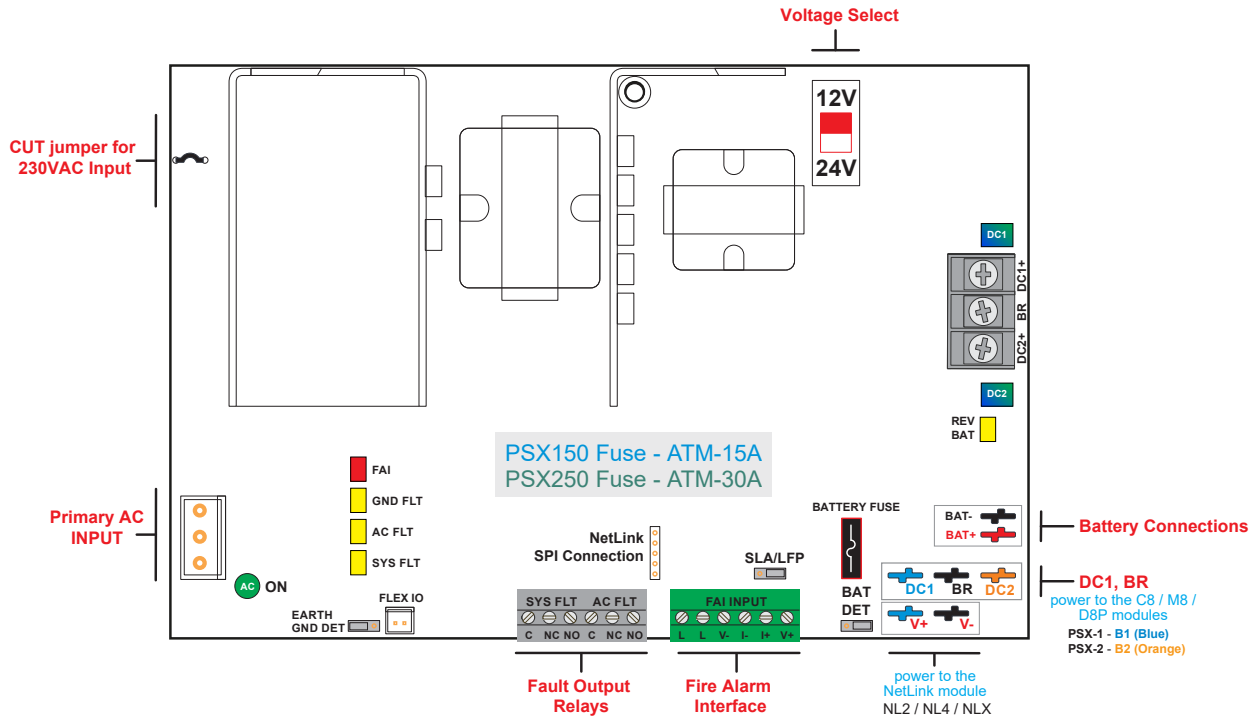

The PSX150 will provide 12V @ 12A or 24V @ 6A and the PSX250 will provide 12V @ 20A or 24V @ 10A. The output voltage is selectable by the slide switch in the upper right corner of the unit. Either unit will charge 4 to 80 Ah of battery capacity.

Voltage from this device is available throughout the system from the C8/M8 lock control boards and the D8 power distribution boards.

AC and System Fault output relays of the PSX power supply are wired to the iSTAR GCM, and a fire alarm interface is available for lock over ride in the event of a fire condition. The fire over ride is applied to the C8/M8 lock control boards as needed and programmed.

See the supplied manual for more information.

Typical Wiring - PSX75

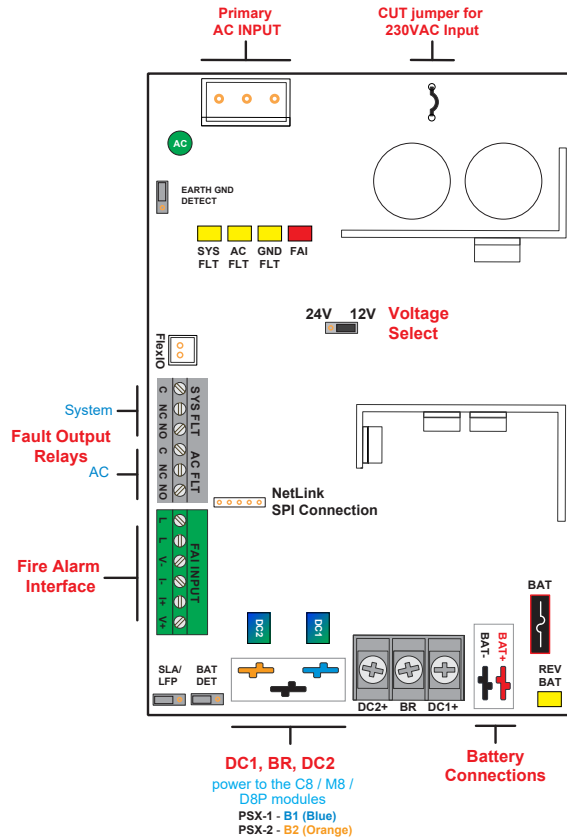

The PSX75 will provide 12V @ 6A or 24V @ 3A. The output voltage is selectable by the two position jumper in the center of the unit. The PSX75 will charge 4 to 40 Ah of battery capacity.

Voltage from this device is available throughout the system from the C8/M8 lock control boards and the D8 power distribution boards.

AC and System Fault output relays of the PSX power supply are wired to the iSTAR GCM, and a fire alarm interface is available for lock over ride in the event of a fire condition. The fire over ride is applied to the C8/M8 lock control boards as needed and programmed.

See the supplied manual for more information.

Typical Wiring - B100

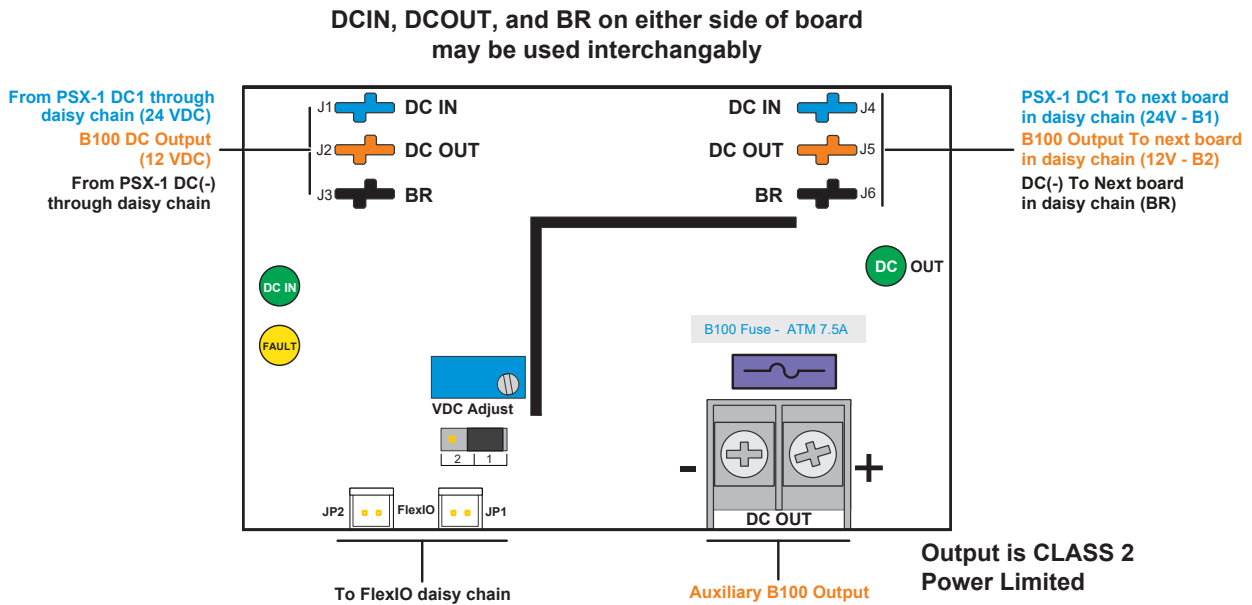

The B100 is used to provide 12V system power when the necessary current is less than 4A. The advantages of using the B100 over a PSX power supply are that the B100 is physically smaller for more effective space utilization, more economical, and does not require a separate standby battery for 12V backup. Input power for the B100 is derived from PSX-1, which is set for 24V, rather than the AC line.

The B100 provides onboard visual indication of an operational or output fault and will transmit that fault condition to the host PSX power supply in the system for activation of the PSX system fault relay. A system fault alert will be provided by the NL4 if installed in the system.

The B100 is rated as a Low Voltage, Class 2, power Limited unit.

For more information, see the provided B100 manual and LSP Application Note AN-07.

Typical Wiring - D8

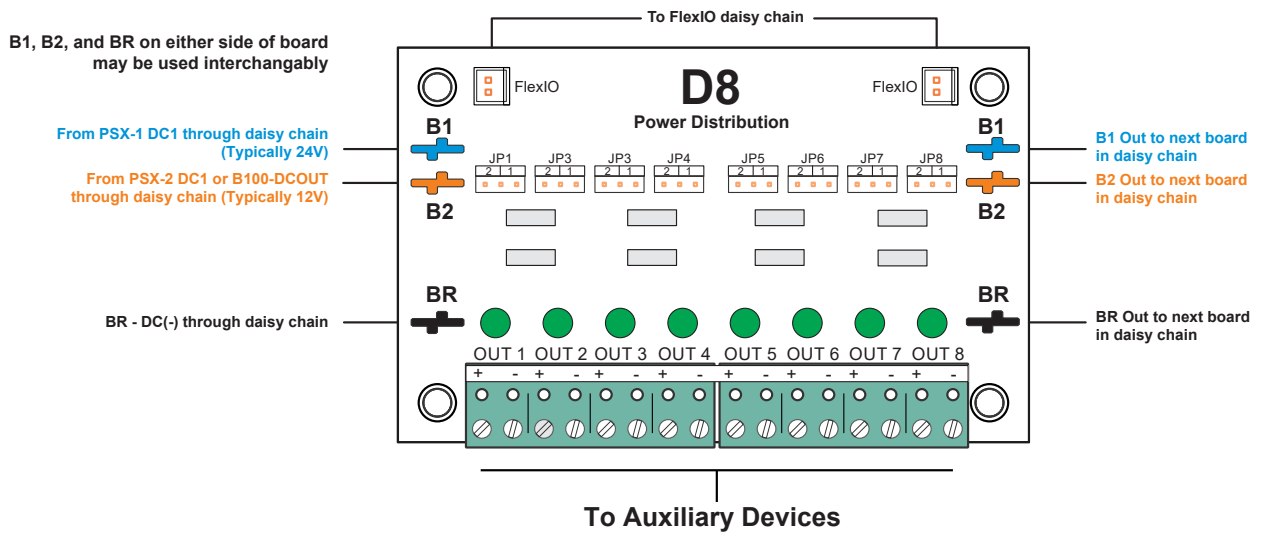

The D8 provides continuous auxiliary outputs. One or more D8 boards may be provided for external auxiliary power. The terminal strips on these D8 boards will be empty and available for powering any 12V or 24V field devices requiring continuous power.

Jumpers JP1 through JP8 are used to select the output voltage for each output in dual voltage systems. Position 1 selects the voltage connected to the B1 buss, while position 2 selects the voltage on the B2 buss. Single voltage systems should leave these jumpers in position 1.

In dual voltage systems, B1 is 24V and B2 is 12V, as set from the factory.

See the D8 manual provided for more information.



Typical Wiring - C8

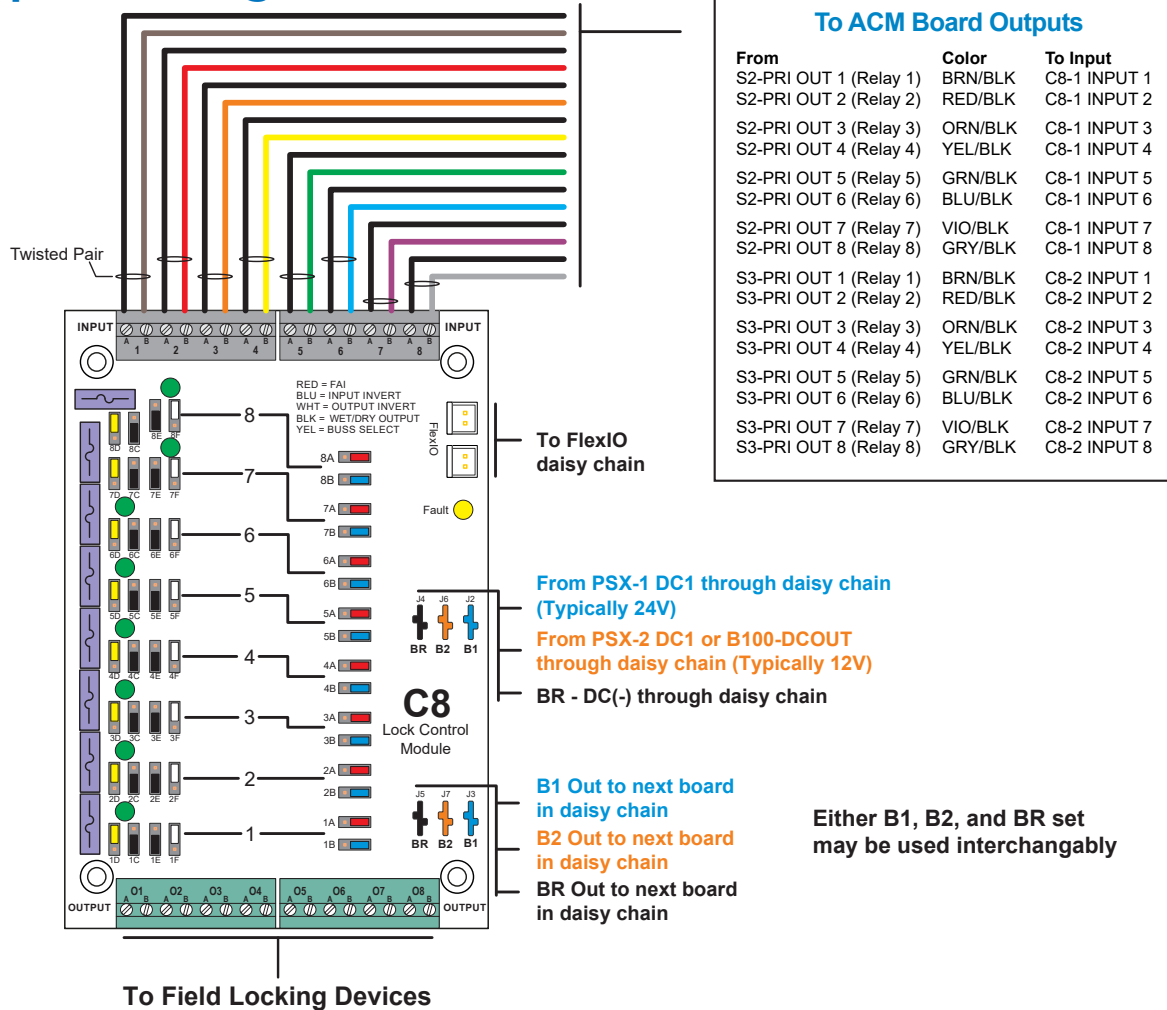

The C8 provides a protective and operational buffer between the access control boards and field induced problems or issues.

Eight trigger inputs are pre-wired to the access control lock outputs with color-coded, twisted-pair wires and eight relay controlled outputs are provided for lock control. Each output is capable of 3A of current and is selectable for either voltage in dual volt-age systems.

The blue and black jumpers are pre-set from the factory. The jumpers below need to be set by the installer. See the included C8 manual and LSP Application Note AN-29 for more information.

Color	Function	Position 1	Position 2
Red	FAI	Enabled	Disabled
Yellow	Voltage Select	B1	B2
White	Lock Type	Maglock (Fail Safe)	Strike (Fail Secure)

Typical Wiring - M8

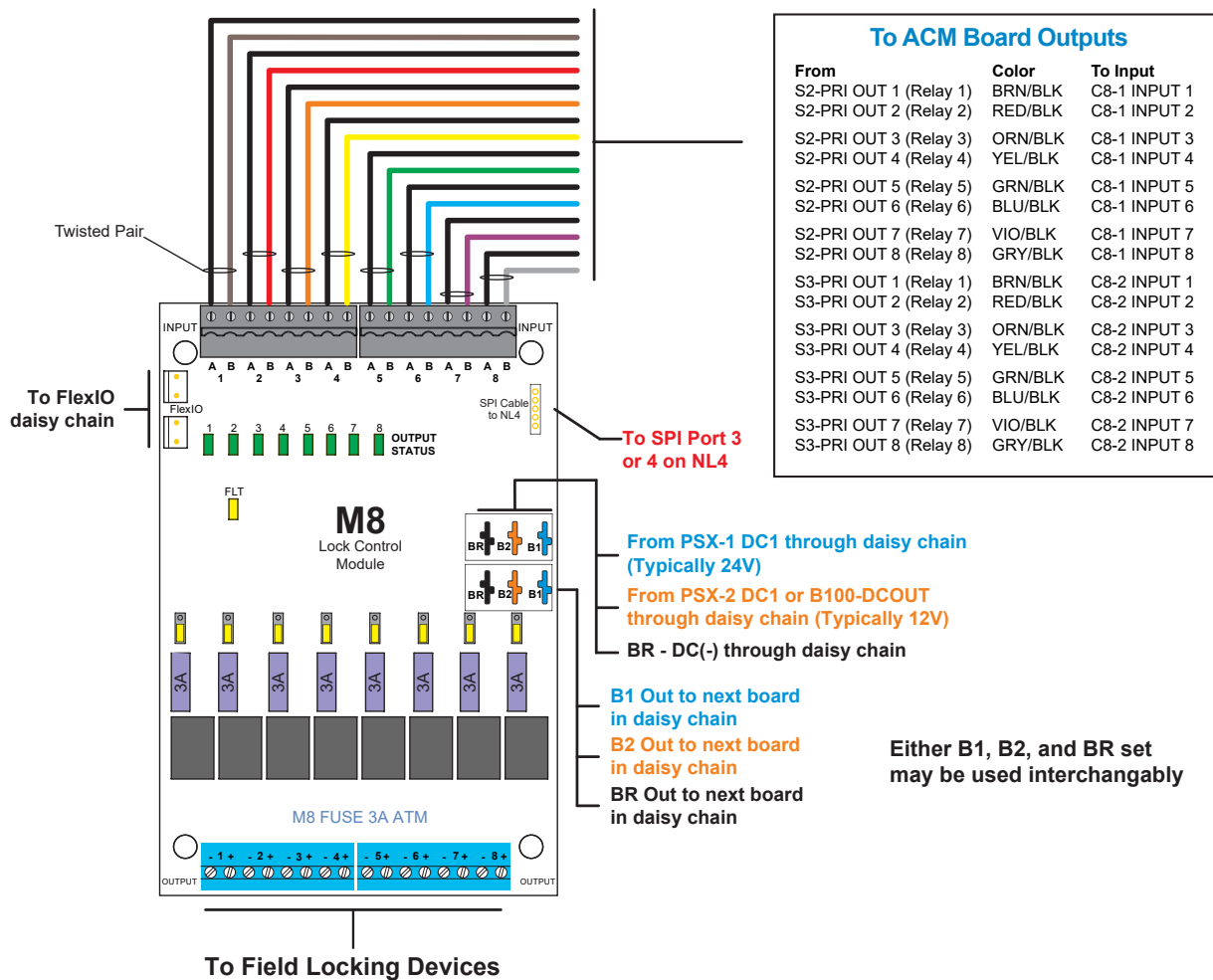

The M8 provides a protective and operational buffer between the access control boards and field induced problems or issues. This unit is used for lock control when a network managed system is desired with remote control, reporting, and diagnostics.

Eight trigger inputs are pre-wired to the access control lock outputs with color-coded, twisted-pair wires and eight relay controlled outputs are provided for lock control. Each output is capable of 3A of current and is selectable for either voltage in dual voltage systems.

System configuration, FAI Operation, and lock operation are selectable through the embedded browser interface of the required NL4. One jumper per zone is provided for voltage selection in dual voltage systems. See the included M8 and NL4 manuals for more information.

Typical Wiring - NetLink NL4

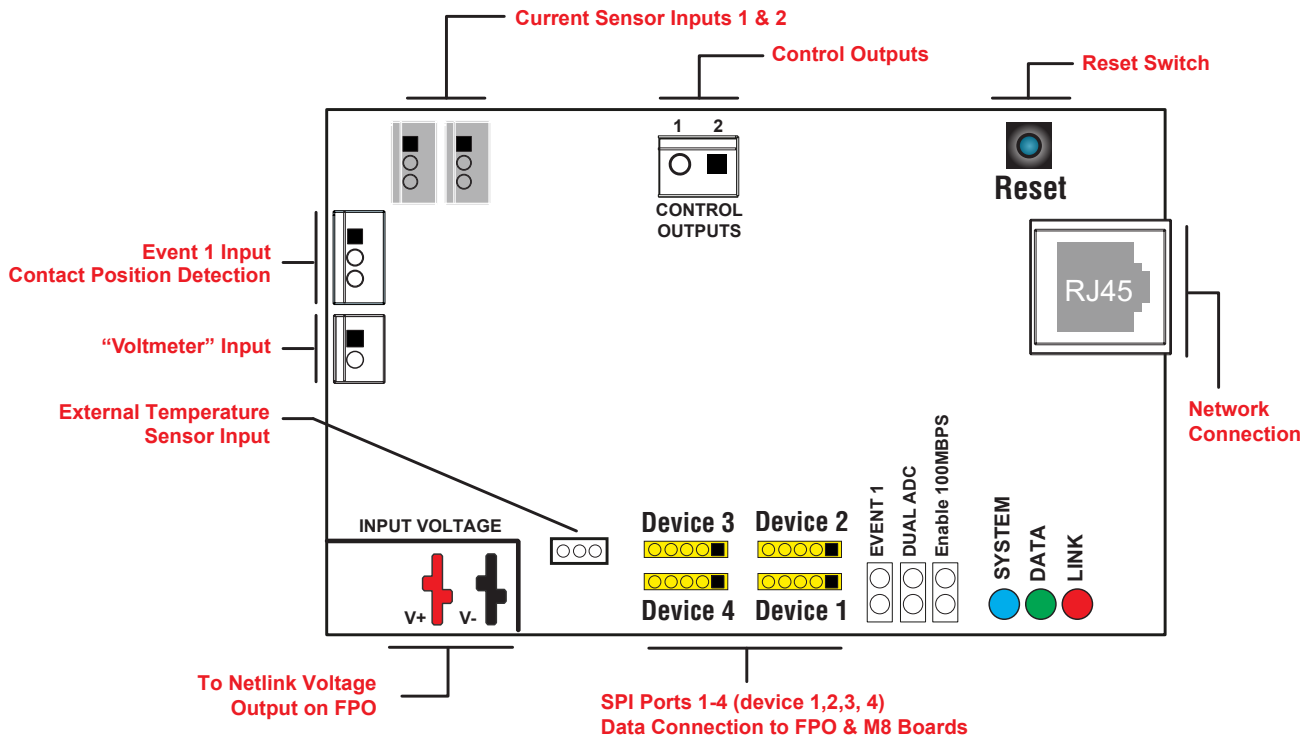

The NL4 is a network module that allows status communication and power control over a local or wide area network. The NL4 provides four device ports for connection to other Flex-Power devices. Data monitored includes fault status, power supply output voltage, battery voltage and charging current, and FAI status. When used with an M8 output board, the NL4 allows control of each individual output, along with the ability to view voltage and current for each output.

In addition to the four device ports, the NL4 also includes two current sensors, a voltmeter input, an external temperature sensor, and a contact monitor input. Upper and lower limits can be set for these inputs to provide an alert if the sensor goes out of range.

A 1000 point history data log updates at the selected interval and is emailed on a status change. The data log can also be set to send on a selected schedule.

See the provided NL4 manual and LSP Application notes AN-20, AN-23, AN-24, and AN-25.



Power is knowledge.™

LifeSafety Power®

SWH PSX
PRE-WIRED

For more information about the ProWire™ System:
www.lifesafetypower.com
PH 888.577.2898

© 2024 LifeSafety Power. All rights reserved. LifeSafety Power, FlexPower and ProWire are registered trademarks of LifeSafety Power or its affiliates. Product specifications are subject to change without notice. This material is provided for informational purposes only; LifeSafety Power assumes no liability related to its use.